

**INSTRUCTIONS**  
**FOR**  
**CONTINUED AIRWORTHINESS**

**FOR**  
**GROVE MAIN WHEEL**  
**AND**  
**BRAKE ASSEMBLIES**  
**WITH**  
**FAA-TSO APPROVAL**

**DOCUMENT 13046-11**  
**Rev C**

**April 29, 2018**

# TABLE OF CONTENTS

SECTION	PAGE
Title Page.....	1
Table of Contents.....	2
Introduction .....	3
<b>BRAKE CALIPER INSPECTION AND MAINTENANCE.....</b>	<b>4</b>
1. Visual Inspection .....	4
2. Brake Linings — Inspection and Replacement .....	5
2.1. Removal of Brake Caliper Assembly .....	5
2.2. Inspection and Installation of New Linings .....	6
2.3. Reinstallation of Back Plate and Press Plate Assemblies.....	6
3. Brake Caliper — Removal, Inspection and Repair.....	7
3.1. Removal and Disassembly of the Brake Caliper.....	7
3.2. Inspection and Repair.....	7
3.3. Reassembly and Reinstallation of the Brake Caliper Assembly.....	8
3.4. Bleeding the Brakes.....	9
3.5. Conditioning the Brake Linings .....	9
<b>WHEEL ASSEMBLY INSPECTION AND MAINTENANCE .....</b>	<b>10</b>
4. Visual Inspection .....	10
5. Maintenance and Repair.....	10
5.1. Removal of the Wheel Assembly .....	10
5.2. Disassembly of the Wheel .....	11
5.3. Inspection and Repair.....	11
5.4. Reassembly of the Wheel.....	13
5.5. Reinstalling the Wheel on the Aircraft.....	15
6. Special Instructions for Tubeless Wheels .....	16
<b>TROUBLE SHOOTING.....</b>	<b>19</b>

## INTRODUCTION

This document provides installation and continued airworthiness instructions for Grove Main Wheel & Brake assemblies with FAA-TSO approval. These articles have been tested to meet the requirements of TSO-C26d but do not have installation eligibility for specific aircraft.

As such, this is not an FAA approved document, but rather a guide for aircraft manufacturers and others who obtain installation eligibility on their aircraft. The information contained herein will be helpful to these persons as a basis to amend and include in their approved installation and continued airworthiness documents.

The following paragraphs detail the inspection and repair processes for these articles. Information regarding specific part numbers and tolerances can be found at [groveaircraft.com](http://groveaircraft.com) under [Wheels & Brakes | Maintenance Instructions](#).

Figure 1 below shows the main components of a typical Grove Main Wheel & Brake assembly.

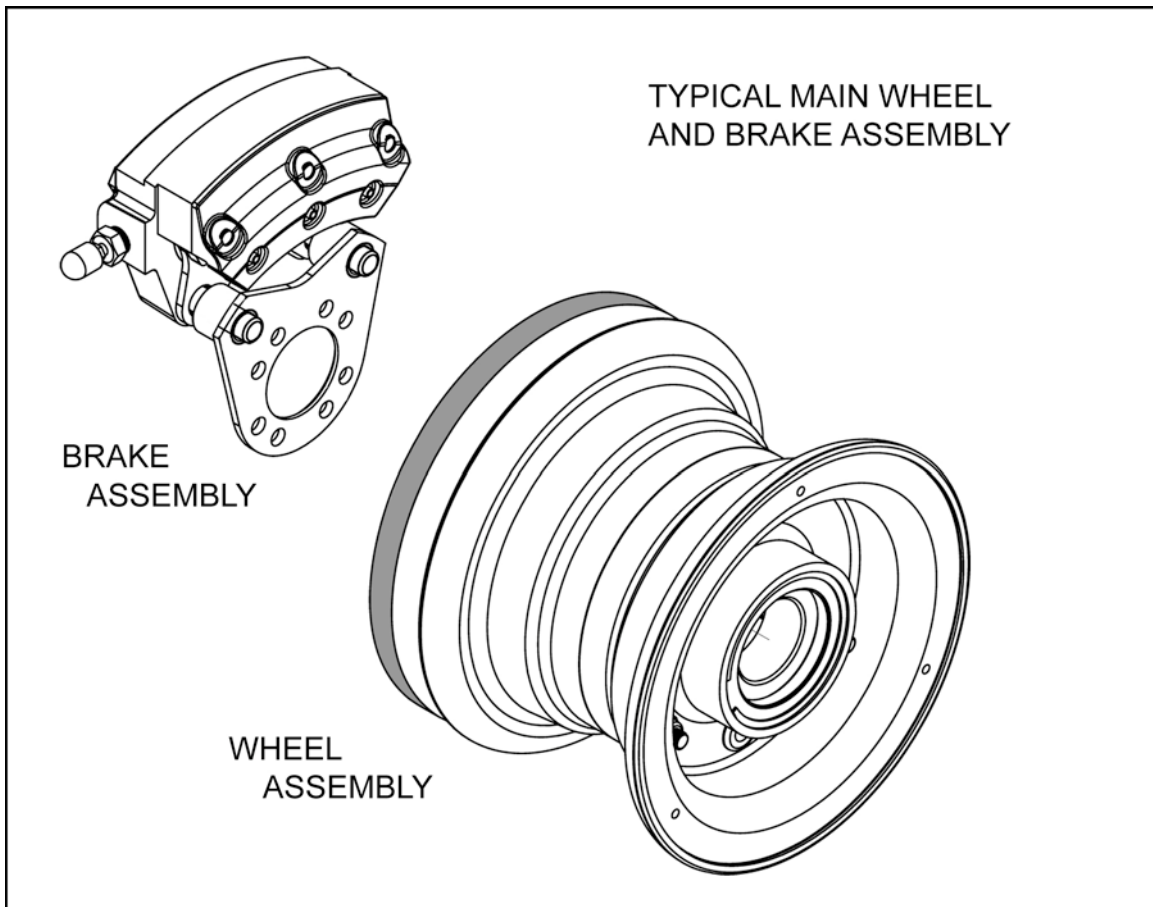

Figure 1

# BRAKE CALIPER INSPECTION AND MAINTENANCE

The brake linings and caliper can be inspected, maintained and repaired without raising the aircraft or removing the wheel. Instructions for installation on the aircraft can be found in section 3.3. Failure of any of the following inspections will require maintenance and/or repair as detailed in the following sections.

**NOTE:** If the brake assembly has experienced undue loads or stress, such as a ground loop, the assembly must be replaced.

## 1. VISUAL INSPECTION

- 1.1. Visually inspect the caliper for corrosion, leaking hydraulic fluid, cracks or visible damage.
- 1.2. Check back plate tie bolts to ensure that they are properly torqued, safety wired and have not worked loose.
- 1.3. Visually check torque plate for corrosion, cracks and loose bolts that attach the torque plate to the axle.
- 1.4. Visually check brake linings (pads) for wear. Linings worn to less than 0.100" must be replaced.

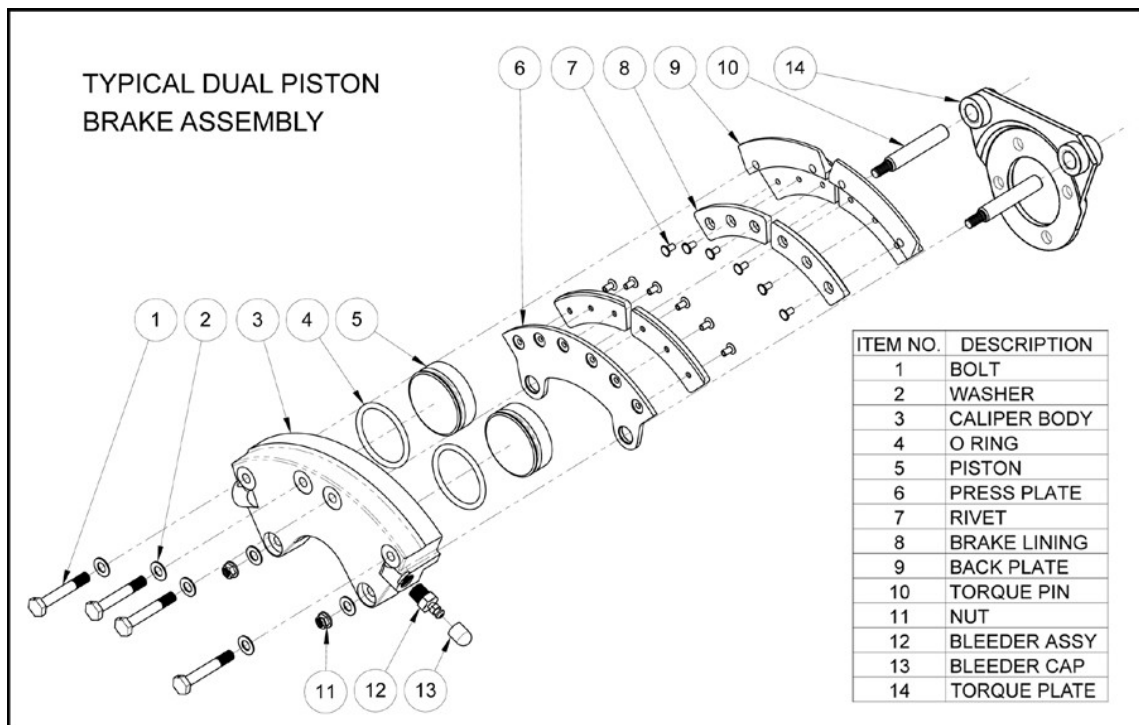

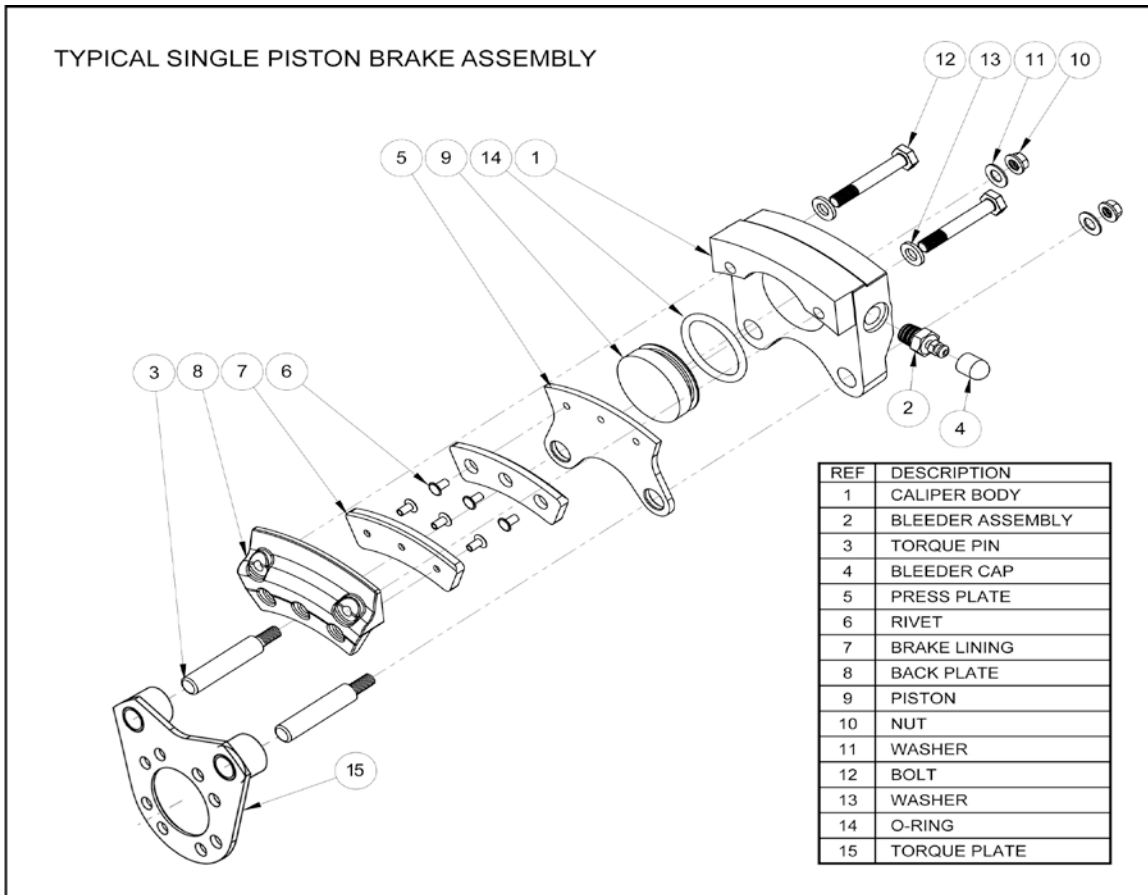

- 1.5. Check brake line and brake line fittings for signs of damage or leakage. If the linings have been contaminated with fluid, they should be replaced.
- 1.6. If any conditions specified in paragraphs 1.1. through 1.5. above are observed, repair and/or replacement is required as specified in the following sections.

## 2. BRAKE LININGS — INSPECTION AND REPLACEMENT

### 2.1. Removal of Brake Caliper Assembly

- 2.1.1. Remove back plate tie bolts and remove back plate assembly.
- 2.1.2. Slide brake caliper out of torque plate assembly. Removal of the brake line may not be necessary. If removal of the brake line is necessary, cap or plug the hydraulic lines to prevent entry of contaminants. After reinstallation of the brake caliper, bleed the brakes in accordance with paragraph 3.4.
- 2.1.3. Slide press plate assembly off of the torque pins.

## **2.2. Inspection and Installation of New Linings**

If linings are worn to less than 0.100", are excessively pitted, heat damaged, oil soaked, or exhibit other damage they must be replaced as follows:

- 2.2.1. Remove old linings by removing the rivets with a small drift punch or 1/8" diameter drill. Use care to prevent elongating the holes in the back plate or press plate. De-burr the holes after drilling if necessary.
- 2.2.2. Clean back plate and press plate surfaces with solvent and air dry before installing new linings.
- 2.2.3. Inspect back plate and press plate for excessive corrosion, visible damage, or excessive warpage. Straighten or replace press plate if warped in excess of 0.010".
- 2.2.4. Rivet new linings onto back plate and press plate using rivet tool #824 or equivalent. Refer to [groveaircraft.com](http://groveaircraft.com) | Wheels & Brakes | Maintenance Instructions for proper linings and rivets. Small cracks in the tubular rivets are allowed after forming, providing that no cracks extend beyond the crest of the rounding. There may be no more than two cracks in any 90 degree segment and no more than three cracks total.
- 2.2.5. Check to ensure that pads are tight to the back plate and press plate, and free from any movement.

## **2.3. Reinstallation of Back Plate and Press Plate Assemblies**

If disassembly or repair of the caliper is necessary, refer to paragraph 3, otherwise reinstall the caliper as follows:

- 2.3.1. Wipe dirt, grease, etc. from brake cylinder and piston and push piston back into cylinder.
- 2.3.2. Clean torque pins and lightly lubricate with a dry film such as silicon spray. Grease will attract dirt and may cause excessive wear on the torque pins and press plate.
- 2.3.3. Slide press plate onto torque pins and install brake caliper assembly onto torque plate.
- 2.3.4. Position back plate between tire and brake disc. Install and tighten tie bolts and washers using the torque value found on the caliper label. Safety wire the back plate tie bolts.
- 2.3.5. If you have disconnected the hydraulic lines, bleed the brake system in accordance with paragraph 3.4.

### **3. BRAKE CALIPER — REMOVAL, INSPECTION AND REPAIR**

#### **3.1. Removal and Disassembly of the Brake Caliper**

Removal of the wheel is not necessary unless the torque plate is to be removed. Disassembly should be done on a clean, cushioned flat surface to prevent nicks, scratches, and gouges to the brake parts.

3.1.1 Drain the fluid from the brake system by opening the bleeder fitting and pumping the brake pedal until the system is dry. Collect the discharged fluid and dispose of properly.

3.1.2. Disconnect brake line from brake caliper. Cap the brake line to prevent entry of foreign material.

3.1.3. Remove the back plate.

3.1.4. Remove the piston from the caliper body. This can be done by injecting compressed air through the brake line fitting. Care must be taken to ensure that the piston does not exit at high velocity. Slowly introduce the air at low pressure and cover the piston and caliper with a rag and/or place face down on a soft surface.

3.1.5. Remove the O-Ring from the piston. It is recommended that new O-Rings be installed. If the old O-Rings are to be re-used, care must be taken to ensure that they are not damaged during removal or re-installation. If the O-Ring is brittle, nicked, scratched or has flat surfaces, it must be replaced. Refer to [groveaircraft.com](http://groveaircraft.com) | Wheels & Brakes | Maintenance Instructions for the proper O-Ring to use. O-Rings must be compatible with MIL-PRF-5606 hydraulic brake fluid.

3.1.6. If removal of the torque plate is required, first remove the wheel as described in paragraph 5.1., then unbolt the torque plate.

#### **3.2. Inspection and Repair**

3.2.1. Visually inspect caliper for cracks, nicks, corrosion, or other damage. Cracks around the torque pins are cause for replacement.

3.2.2. Inspect the caliper torque pins for excessive wear, proper tightness, cracks in the caliper body or other damage. Cracks in the caliper body or loose torque pins are cause for rejection of the caliper body.

3.2.3. Inspect the piston bore and piston for contamination, corrosion and scratches. Light nicks and scratches can be removed by polishing. Care must be taken not to damage the protective coating which will result in increased corrosion. Deep nicks or scratches are cause for rejection of the part.

- 3.2.4. Inspect back plate and press plate for excessive corrosion, visible damage, or excessive warpage which is cause for rejection of the part. Straighten or replace press plate if warped in excess of 0.010”.
- 3.2.5. Inspect the torque plate for corrosion and cracks. Excessive corrosion or cracks are cause for rejection of the part.

### **3.3. Reassembly and Reinstallation of the Brake Caliper Assembly**

- 3.3.1. Clean the brake parts, with the exception of the O-Rings and linings, in solvent and air dry.
- 3.3.2. Carefully install a new O-Ring, or serviceable O-Ring, on the piston using aircraft hydraulic fluid, Dow 55M O-Ring Lubricant or equivalent.
- 3.3.3. Lightly coat the piston bore with aircraft hydraulic fluid, Dow 55M O-Ring Lubricant or equivalent, and carefully place the piston into the caliper. The side of the piston with the O-ring closest to the surface goes in first. Insert it until the top of the piston is flush with the caliper body.
- 3.3.4. Slide the press plate onto the torque pins with the linings facing away from the caliper body.
- 3.3.5. If the torque plate was removed, reinstall in its original, clocked position.
- 3.3.6. Slide the caliper assembly onto the torque plate on the aircraft.
- 3.3.7. Install the back plate, torque the back plate bolts to the value indicated on the brake caliper label and safety wire.
- 3.3.8. Reconnect the hydraulic lines.



### **3.4. Bleeding the Brakes**

- 3.4.1. All Grove brake systems incorporate Buna-N (Nitrile) O-Ring seals that are compatible with MIL-H-5606 (MIL-PRF-5606) hydraulic fluid or its newer replacements: MIL-PRF 83282 and MIL-PRF-87257. All of these fluids are miscible and can be used with each other.
- 3.4.2. Remove the vent plug from the brake system reservoir.
- 3.4.3. Connect a clean hydraulic pressure source such as a hydraulic hand pump to the bleeder valve on the lower end of the brake caliper.
- 3.4.4. Open the bleeder valve one-half turn.
- 3.4.5. Pump hydraulic fluid into the system observing the level in the brake system reservoir. When the reservoir is nearly full, tighten bleeder fitting and remove hydraulic pressure source.
- 3.4.6. Replace and tighten brake system reservoir vent plug.
- 3.4.7. Apply hard pressure to the brake pedal. Check to ensure that you have a "hard pedal" and that there are no leaks. You may have to pump the brake pedal several times
- 3.4.8. If a "soft pedal" condition exists, repeat steps 3.4.2. through 3.4.7.

### **3.5 Conditioning the Brake Linings (Pads)**

These non-asbestos organic composition brake pads require a thin layer of glazed material at the lining friction surface in order to provide maximum braking performance. This glazed layer is produced by the heat generated during normal braking operations, and is maintained during the life of the lining. Since new brake pads do not have this layer, it must be created by the following process:

- 3.5.1. Heat the pads by "dragging the brakes" while taxiing at a slow speed with moderate power. Do not use maximum braking pressure.
- 3.5.2. Allow the brakes to cool for 5 - 10 minutes
- 3.5.3. Test the results at full static run-up. If the brakes hold, break-in is complete. If they fail to hold, repeat steps 1 and 2 until they do.
- 3.5.4. NOTE: The brake linings will continue to "break-in" during normal operations. Typically, after several take offs and landings, the linings will have better stopping performance than when new.

## WHEEL ASSEMBLY INSPECTION AND MAINTENANCE

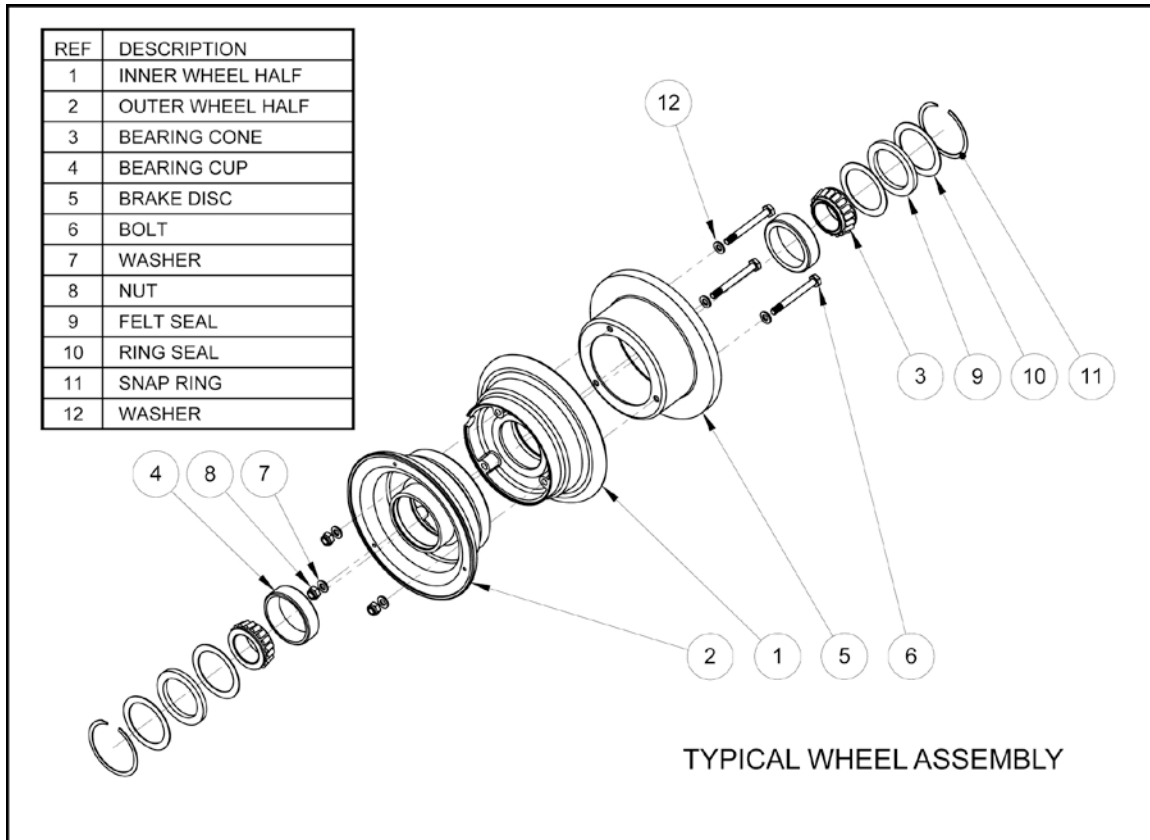

### 4. VISUAL INSPECTION

Failure of any of the following inspections will require maintenance and/or repair as detailed in the following sections.

- 4.1. Insure that the wheel tie bolts are secure and have not worked loose.
- 4.2. Visually inspect the wheels for corrosion, cracks, or other visible damage.
- 4.3. Inspect the brake disc for evidence of cracks, corrosion, deep grooves, or other visible damage.

**NOTE:** If the wheel assembly has experienced undue loads or stress, such as a ground loop, the assembly must be replaced.

### 5. MAINTENANCE AND REPAIR

#### 5.1. Removal of the Wheel Assembly

- 5.1.1. Remove wheel hub cap if so equipped.
- 5.1.2. Remove brake caliper back plates. It is not necessary to disconnect the hydraulic line.

- 5.1.3. Jack and secure the aircraft in accordance with manufactures instructions.
- 5.1.4. Ensure that the aircraft is stable.
- 5.1.5. Deflate the tire by depressing the valve stem plunger until no more air escapes.

**CAUTION:** Do not attempt to remove valve stem core, loosen the axle nut, or disassemble the wheel halves until all tire pressure has been released. Failure to do so can result in severe personal injury.

- 5.1.6. Remove the valve stem core.
- 5.1.7. Remove the axle cotter pin and axle nut.
- 5.1.8. Carefully slide the wheel assembly off of the axle.

## 5.2. Disassembly of the wheel

- 5.2.1. Place the wheel assembly on a clean flat working surface. Care must be taken to prevent damage to the wheel such as scratches and/or nicks which will destroy the corrosion resistant protection of the wheel.
- 5.2.2. Separate the tire beads from the wheel halves using a tire bead breaker or other suitable tool. Do not pry between the tire and wheel flange as damage to tire and/or wheel may occur.
- 5.2.3. Remove the nuts, washers and bolts that hold the wheel halves together.
- 5.2.4. Separate and remove the brake disc from the inner wheel half.
- 5.2.5. Separate each wheel half from the tire using care to not damage the inner tube or its valve stem.
- 5.2.6. Remove the retaining snap rings, washers, felt grease seals and wheel bearings using care to prevent damage to the wheel or bearings.

## 5.3. Inspection and Repair

- 5.3.1. Inspect the bearing races for scoring, corrosion, signs of over heating or other physical damage. Loose bearing races are cause for rejection of the wheel half. If replacement of the race is necessary, carefully press it out using a press and properly sized bushings as illustrated.

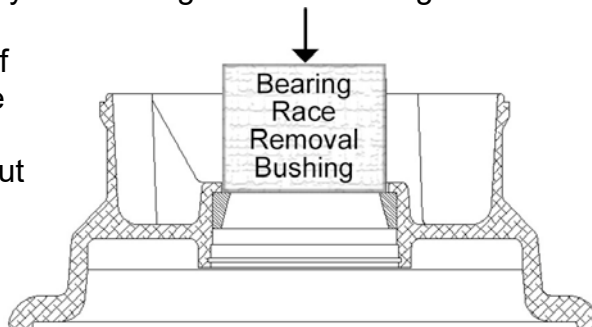

- 5.3.2. Visually inspect each wheel half for cracks, nicks, corrosion or other damage. Particular attention should be paid to the tire bead seat area. Obvious cracks and severe corrosion are cause for rejection of the part. A further inspection using the dye penetrant method should be performed on any part whose serviceability is questionable. Small nicks, scratches and pits may be blended out and polished with fine (400 grit) sandpaper and then painted and/or treated for corrosion resistance.
- 5.3.3. Clean the wheel bearings in a suitable solvent and air dry using compressed air being careful to not allow the compressed air to spin the bearings.
- 5.3.4. Inspect the bearings for pitting, cracks, evidence of overheating, or excessive corrosion, any of which is cause for rejection of the part.
- 5.3.5. Inspect the felt grease seals. Excessively worn, hardened or contaminated seals are cause for replacement. Serviceable seals should be cleaned in solvent, air dried, and set aside in a clean, protected environment until required for reassembly.
- 5.3.6. Inspect the felt seal retaining washers and snap rings for distortion, excessive corrosion or other physical damage which is cause for rejection.
- 5.3.7. Inspect wheel tie bolts for cracks, bending, thread damage, or excessive corrosion, any of which is cause for rejection. The tie bolts are subjected to fatigue type loads and should be replaced whenever there is any question as to their serviceability.
- 5.3.8. Test the wheel tie bolt nuts by temporarily installing them onto the bolts. If the nut can be turned by hand past the self-locking section, it must be replaced.
- 5.3.9. Inspect brake disc for excessive wear, scoring, or corrosion, cracks, warpage, or other physical damage which is cause for rejection of the part. Minor corrosion and surface irregularities can be blended using 220 grit sandpaper. Any corrosion on the non-braking part of the disc should be removed and then painted and/or treated for corrosion resistance.
- 5.3.10. Measure disc thickness. Minimum disc thickness can be found at [groveaircraft.com](http://groveaircraft.com) | Wheels & Brakes | Maintenance Instructions. If the disc thickness is less than minimum, the disc must be replaced.

## 5.4. Reassembly of the Wheel

- 5.4.1. Reassembly of the wheel is basically the reverse of the disassembly process. Assemble the wheel on a clean, flat surface being careful to not nick, scratch, or damage the protective finish of the wheel.
- 5.4.2. Reinstall the bearing races if applicable. Heating the wheel and/or cooling the bearing race is of minimal benefit in the installation process.
- 5.4.3. Clean the wheel bearing race bore and apply a thin coat of wheel bearing grease.
- 5.4.4. Place the bearing race in the wheel bore, being careful to insure that it is aligned properly and not cocked.

- 5.4.5. Place the wheel half in the press as shown in the adjacent figure being sure to support the wheel half at the bottom of the bearing seat.

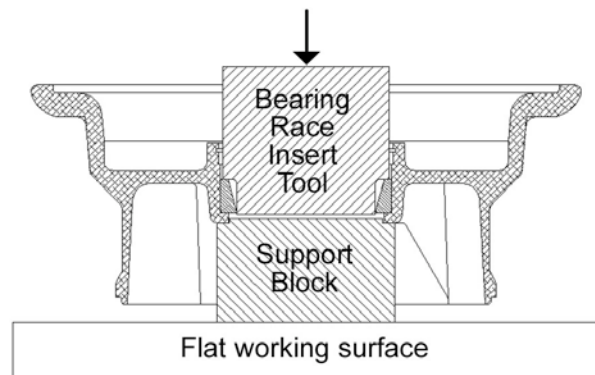

Failure to do so may result in breakage of the wheel casting if too much force is applied.

- 5.4.6. Press the bearing race into the wheel until it is fully seated.
- 5.4.7. Remove the wheel from the press and visually check to see that the race is fully seated and that it is tight in the wheel.
- 5.4.8. Prior to mounting the tire on the wheel, ensure that the wheel is clean and dry. Particular attention should be paid to the bead seat area to ensure that it is clean, dry and free of grease or other contamination which may cause the tire to spin on the wheel as the brakes are applied.
- 5.4.9. Insert the inner tube into the tire. Align the red dot on the tire (its lightest point) with the white or yellow dot on the tube (its heaviest point). If the tube does not have a white dot, align the red dot on the tire with the valve stem of the tube. In order to allow the tube to move freely within the tire, it is recommended that you coat the tube and inner part of the tire with talc powder.
- 5.4.10. Inflate the inner tube to approximately 10 psi, allowing it to take the shape of the tire. Deflate the tube to the point that it just retains its shape.
- 5.4.11. Place the tire and tube onto the outer wheel half carefully inserting the valve stem through the hole in the wheel half.

- 5.4.12. Insert the inner wheel half into the tire with the tie bolt holes aligned and using care not to pinch the inner tube.
- 5.4.13. Place the wheel and tire assembly on a flat working surface with the inboard side of the wheel facing up. Install the brake disc in the inner wheel half and align the bolt holes with the wheel half. Insert the tie bolts, with washers under the heads, through the brake disc and wheel.
- 5.4.14. Rotate the wheel from the working surface in order to be able to attach the nuts to the tie bolts. Hand tighten a nut with washer on each of the tie bolts. Care should be taken to ensure that the wheel halves are in contact with each other and not pinching the inner tube.
- 5.4.15. Torque the tie bolt nuts to the value indicated on the wheel label. Observe the amount of torque required to turn the nut due to the locking friction of the nut and add this to get the proper torque wrench reading.
- 5.4.16. Grove wheels are shipped with only a light coating of wheel bearing grease. You must re-pack the bearings using MIL-G-81322 grease such as Aeroshell 22, Mobil 28, or equivalent.
- 5.4.17. With the wheel on a flat working surface, lightly coat the bearing race with bearing grease, then place the re-packed wheel bearing into the bearing race.
- 5.4.18. Install the washers, felt grease seal and retention snap ring. A light coat of light weight oil on the felt grease seal is recommended.
- 5.4.19. Turn the wheel over and repeat steps 17 and 18.
- 5.4.20. Place the wheel in a protective enclosure and inflate to 60 psi. Deflate the tire by depressing the valve stem plunger and re-inflate to the pressure recommended by the aircraft manufacturer.

## **5.5. Reinstalling the Wheel on the Aircraft**

- 5.5.1. Inspect the axle to ensure that it is clean, dry and in serviceable condition.
- 5.5.2. Slide the wheel onto the axle with the brake disc side inboard.
- 5.5.3. Install axle nut and hand tighten ensuring that inboard wheel bearing is fully seated against the bearing stop on the axle.
- 5.5.4. While slowly rotating the wheel, tighten the axle nut until you feel resistance of the wheel to rotate. Care must be taken to ensure that the valve stem is not damaged during this process.
- 5.5.5. Loosen the axle nut only enough so that the wheel runs free, or with very little drag.
- 5.5.6. Check that a slot in the axle nut aligns with a cotter pin hole in the axle. If you need to move the nut for alignment, first try to tighten it. If the wheel still moves with little or no resistance, use that alignment. If there is significant resistance to rotation, loosen the nut to the next hole.
- 5.5.7. Install cotter pin to safety the axle nut to the axle. Use care to ensure that there is adequate clearance between the cotter pin and the valve stem as the wheel rotates.
- 5.5.8. Reinstall the brake caliper backing plate. Torque the bolts to the value indicated on the label, and safety wire. Refer to section 2.3.
- 5.5.9. Reinstall the wheel hub cap if so equipped.
- 5.5.10. Rotate the wheel to ensure that it is secure and rotates freely.
- 5.5.11. Lower the aircraft to the ground following aircraft manufacturer's instructions.

## 6. SPECIAL INSTRUCTIONS FOR TUBELESS WHEELS

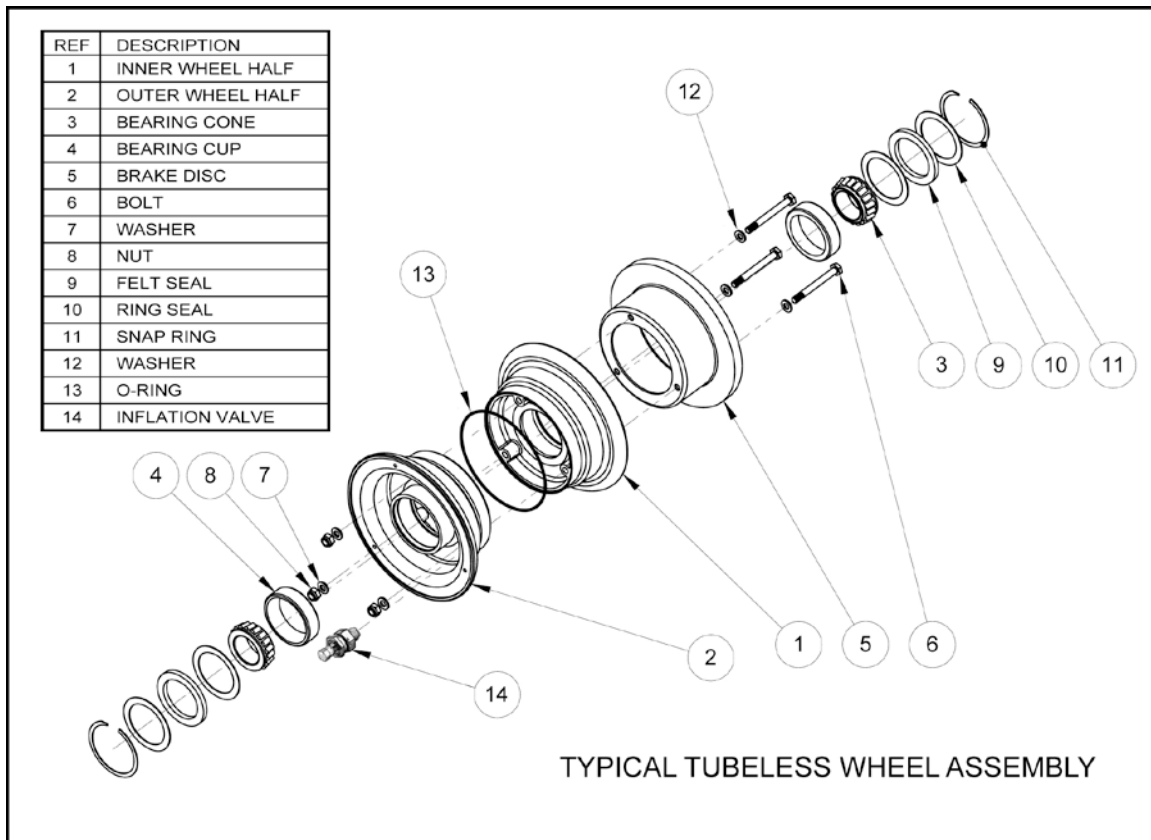

### 6.1 Inspection and Repair of the Tubeless Wheel Assembly

Inspect and Repair the Tubeless Wheel in the same manner as a Tube-type wheel. Refer to sections 4 through 5.3 above.

### 6.2 Reassembly of the Tubeless Wheel Assembly

- 6.2.1 Ensure that the wheel is clean and dry. It is recommended that you clean the bead seat area of both the wheel and tire with isopropyl alcohol to ensure that it is clean, dry and free of grease or other contamination.
- 6.2.2 Examine the tire to ensure that it is of the proper size and that it is in serviceable condition — free of damage or contamination, especially in the bead area.
- 6.2.3 Place the outer wheel half (the half with the inflation valve) on a flat working surface with the inner side of the wheel facing up.
- 6.2.4 Ensure that the O-ring is in serviceable condition or replace with a new one. Clean the O-ring and then lightly coat with wheel bearing grease.



- 6.2.5 Carefully install the O-ring in the wheel half that has the O-ring retaining lip, being careful to not twist it. If the O-ring tends not to stay in its seat, hand-stretching the O-ring may solve this problem.
- 6.2.6 Place the tire onto the outer wheel half, being careful not to disturb the O-ring. The red dot on the tire indicates the tire's lightest point. It should be aligned with the inflation valve on the wheel half.
- 6.2.7 Place the inner wheel half into the tire so that it mates with the outer wheel half, with the tie bolt holes aligned, using care not to dislodge or damage the O-ring.

**NOTE: SPECIAL INSTRUCTIONS FOR 10" WHEELS**

A special installation procedure is required for Grove 100-1007 and 100-1008 ten-inch wheel assemblies. The wheel halves are held together with six tie bolts, but the size and installation order of these is important. When assembling the wheel halves,

FIRST, after following steps 1 through 7 above, install, tighten, and torque the three shorter (AN5-36A) tie bolts through the holes most distant from the center of the wheel. Use AN960-516L (thin) washers under the heads of the bolts, and AN960-516 (regular) washers under the nuts.

THEN attach the brake disc into the inner wheel half using the longer (AN5-37A) tie bolts through the holes closest to the center of the wheel, without washers under the bolt heads and AN960-516 (regular) washers under the nuts

- 6.2.8 Place the brake disc in the inner wheel half, aligning the bolt holes with the wheel half.
- 6.2.9 Insert the tie bolts through the brake disc and wheel halves.
- 6.2.10 Rotate the wheel from the working surface in order to be able to attach the nuts to the tie bolts. Hand tighten a nut with washer on each of the tie bolts. Care should be taken to ensure that the wheel halves are in contact with each other and that the O-ring has not been dislodged or damaged.
- 6.2.11 Torque the tie bolt nuts to the value indicated on the wheel label. Observe the amount of torque required to turn the nut due to the locking friction of the nut and add this to torque requirements to get the proper torque wrench reading.

- 6.2.12 Inflate the tire until the tire beads firmly seat on the wheel halves. If you are having problems with the tire beads seating on the wheel halves, you may try the following procedure.
  - a. Remove the valve core from the valve stem to allow air to enter the tire at a greater rate.
  - b. Tighten a ratchet strap around the circumference of the tire. This often forces the tire bead seats to contact the wheel.
- 6.2.13 After the tire beads are seated, re-install the valve core, if it has been removed, and inflate the tire to the aircraft manufacturer's recommendation.
- 6.2.14 Re-pack and install the wheel bearings and grease seals as described in sections 5.4.16 through 5.4.19 above.

## **5.5. Reinstalling the Wheel on the Aircraft**

Reinstall the wheel on the aircraft as described in section 5.5 above.

**NOTE:** Because proper inflation of aircraft tires affects the tire life and performance, they should be checked on a regular basis and as follows.

After 12 hours after initial inflation, recheck the inflation pressure. Newly mounted aircraft tires expand slightly after inflation, and as the volume of the tire increases, the internal pressure will decrease.

After 24 hours, recheck the tire pressure. It is normal for aircraft tires to lose pressure over time, but if the pressure has decreased more than five percent during this time, you should check for a possible leak and take corrective action.

## TROUBLE SHOOTING

TROUBLE	PROBABLE CAUSE	CORRECTION
1. Unable to obtain sufficient hydraulic brake pressure or spongy pedal	Air in hydraulic system.  Brake pedal binding	Check for source, then bleed hydraulic system IAW section 3.4.  Check for freedom of movement of brake pedal and master cylinder
2. Excessive pedal travel	Incorrect installation Leak in system—brake, master cylinder, fittings, or lines. Defective master cylinder. Back plate bolts loose.	Refer to aircraft manual. Locate leak and repair. Repair or replace. Torque bolts to proper value IAW paragraph 2.3.4.
3. Brake Drag	Piston jammed in caliper  Foreign matter wedged in brakes  Master cylinder not releasing hydraulic pressure  Foreign matter lodged between torque pins and torque plate bushings.  Bent torque plate.  Bent torque pins	Remove caliper and repair cylinder or piston Locate and remove  Check for proper master cylinder installation. Repair or replace master cylinder.  Clean and inspect. Replace if necessary.  Replace torque plate. Replace torque pins.
4. Rapid disc and/or pad wear.	Dragging brakes Excessive rusting, scoring, or pitting of brake disc  Excessive back plate deflection caused by bent bolts or over torquing bolts.	Refer to Trouble #3 Clean or replace disc.  Check torque of bolts IAW paragraph 2.3.4. and replace bolts if bent.
5. Brakes won't hold.	Improper conditioning of brake pads. Contaminated pads. Insufficient hydraulic pressure. Brake pad carburized (overheated)	Condition pads IAW section 3.5. Replace pads. Refer to Trouble #1. Replace pads