

**INSTRUCTIONS FOR CONTINUED
AIRWORTHINESS**

for

**GROVE MODEL
40-108 & 40-208
MAIN WHEELS**

DOCUMENT 12012-12 REV IR

January 16, 2012

TABLE OF CONTENTS

SECTION	PAGE
Title Page	1
Table of Contents	2
Record of Revisions.....	2
1. Introduction.....	3
2. Exploded View of Typical Main Wheel	3
3. Inspection	4
4. Removal of the Wheel Assembly	4
5. Disassembly of the Wheel	5
6. Inspection and Repair	5
7. Reinstalling the Bearing Races if Applicable	6
8. Inspection and Repair of Brake Drum or Brake Disc	6
9. Reassembly of the Wheel	7
10. Reinstalling the Wheel on the Aircraft	8
11. Protective Coatings	8

RECORD OF REVISIONS

This “Record of Revisions” identifies all revisions to this document. When changes to this document are needed, revisions will be issued by the Applicant.

This “Record of Revisions” shall remain in this document at all times. Upon the receipt of revisions, insert the revised page(s) into this document and enter the revision number, revision date, insertion date and signature of person incorporating the revision into the document in the appropriate spaces below.

Revision Number	Description	Pages Affected	Revision Date	Inserted By
IR	Initial Release	1-8	01/16/2012	 Robert P. Grove, Chief Engineer

1. Introduction

This document is designed to provide aircraft technicians with sufficient information to inspect, troubleshoot, adjust, repair, test, remove and install the Grove 40-108 (Aluminum) and 40-208 (Magnesium) Wheel Assemblies.

2. Exploded Views of Main Wheels

These diagrams illustrate each wheel assembly and a listing of their component parts and source.

2.1. Exploded View of Grove 40-108 Aluminum Wheel Assembly

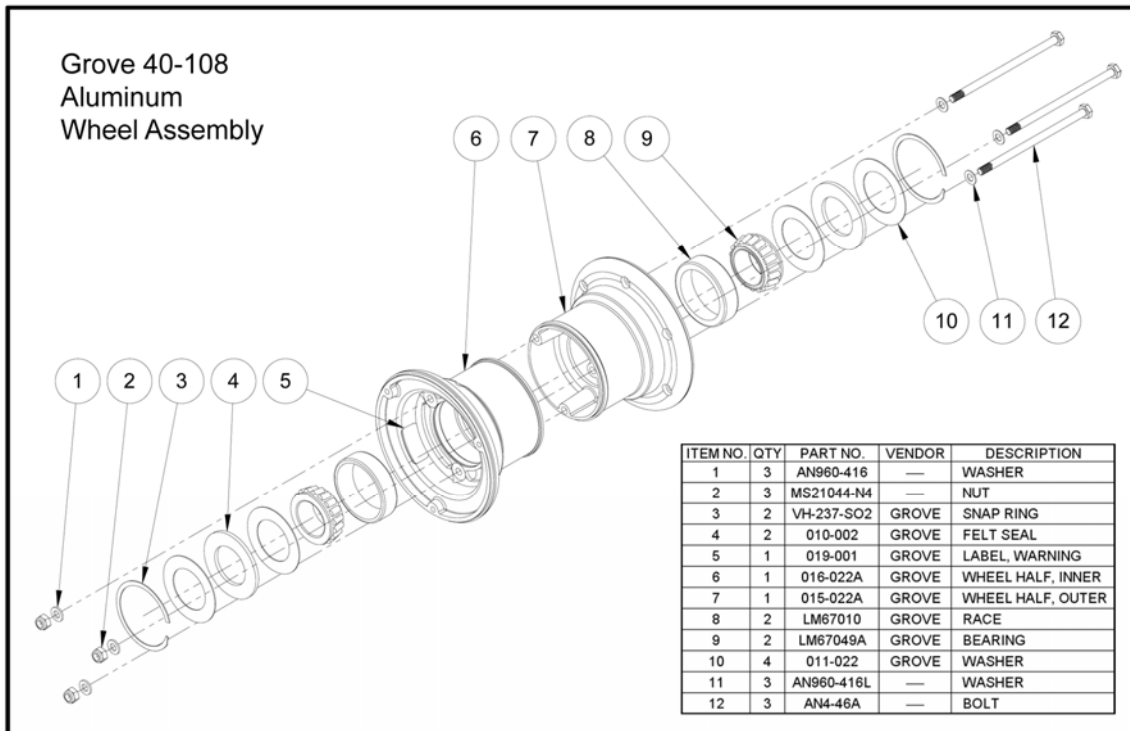

2.2. Exploded View of Grove 40-208 Magnesium Wheel Assembly

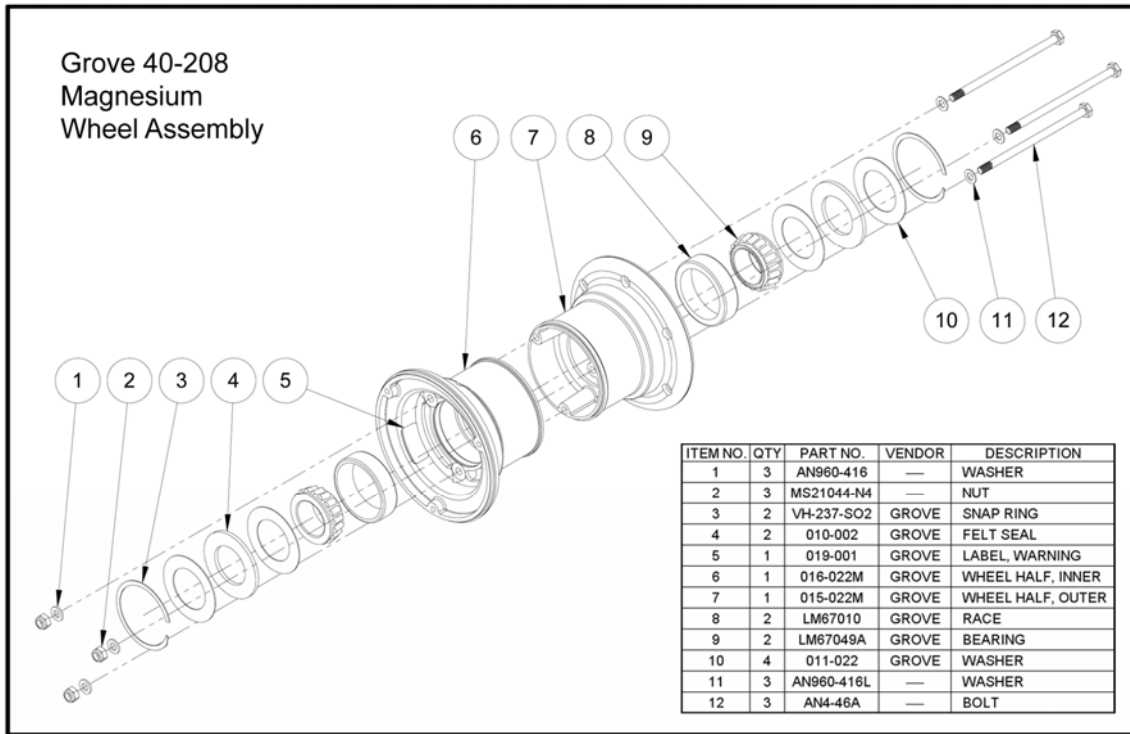

3. Inspection

- 3.1 Prior to each flight, visually inspect the wheel to insure that the wheel tie bolts are secure, that there is no excessive corrosion, cracks or other visible damage. Any indication of these would require the wheel to be further inspected in accordance with section 6.
- 3.2 At each 100 hour and annual inspection, inspect and service the wheel in accordance with section 6.

4. Removal of the Wheel Assembly

- 4.1. Remove wheel hub cap if so equipped.
- 4.2. Jack and secure the aircraft in accordance with the manufacture's instructions.
- 4.3. Ensure that the aircraft is stable.
- 4.4. Deflate the tire by depressing the valve stem plunger until no more air escapes.

CAUTION: Do not attempt to remove valve stem core, loosen the axle nut, or disassemble the wheel halves until all tire pressure has been released. Failure to do so can result in severe personal injury.

- 4.5. Remove the valve stem core.
- 4.5 Remove brake caliper if so equipped.
- 4.6. Remove the axle cotter pin and axle nut.
- 4.7. Carefully remove the wheel assembly from the axle.

5. Disassembly of the Wheel

- 5.1. Place the wheel assembly on a suitable working surface. Care must be taken to prevent damage to the wheel such as scratches and/or nicks which will destroy the corrosion resistant protection of the wheel.
- 5.2. Separate the tire beads from the wheel halves using a tire bead breaker or other suitable tool. Do not pry between the tire and wheel flange as damage to tire and/or wheel may occur.
- 5.3. Remove the nuts, washers and bolts that hold the wheel halves together.
- 5.4. Separate each wheel half from the tire using care to not damage the inner tube or its valve stem.
- 5.5. Remove the retaining snap rings, washers, felt grease seals and wheel bearings using care to prevent damage to the wheel or bearings.

6. Inspection and Repair

- 6.1. Inspect the bearing races for scoring, corrosion, signs of overheating or other physical damage. Loose bearing races are cause for rejection of the wheel half. If replacement of the race is necessary carefully press it out using a press and properly sized bushings as illustrated.

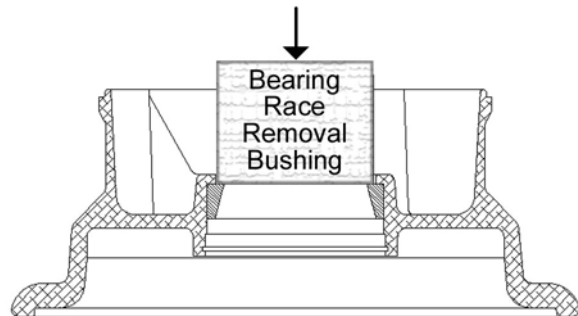

- 6.2. Visually inspect each wheel half for cracks, nicks, corrosion or other damage. Particular attention should be paid to the tire bead seat area. Obvious cracks and severe corrosion are cause for rejection of the part. A further inspection using the dye penetrant method should be performed on any part whose serviceability is questionable. Small nicks, scratches and pits may be blended out and polished with fine (400 grit) sandpaper and then painted and/or treated for corrosion resistance.
- 6.3. Clean the wheel bearings in a suitable solvent and air dry using compressed air being careful to not allow the compressed air to spin the bearings.
- 6.4. Inspect the bearings for pitting, cracks, evidence of overheating, or excessive corrosion, any of which is cause for rejection of the part.

- 6.5. Inspect the felt grease seals. Excessively worn, hardened or contaminated seals are cause for replacement. Serviceable seals should be cleaned in solvent, air dried, and set aside in a clean, protected environment until required for reassembly.
- 6.6. Inspect the felt seal retaining washers and snap rings for distortion, excessive corrosion or other physical damage which is cause for rejection.
- 6.7. Inspect wheel tie bolts for cracks, bending, thread damage, or excessive corrosion, any of which is cause for rejection. The tie bolts are subjected to fatigue type loads and should be replaced whenever there is any question as to their serviceability.
- 6.8. Test the wheel tie bolt nuts by installing them onto the bolts. If the nut can be turned by hand past the self-locking section, it must be replaced.

7. Reinstalling the Bearing Races if Applicable.

NOTE: Heating the wheel and/or cooling the bearing race is of minimal benefit in the installation process.

- 7.1. Clean the wheel bearing race bore and apply a thin coat of wheel bearing grease.
- 7.2. Place the bearing race in the wheel bore, being careful to insure that it is aligned properly and not cocked.
- 7.3. Place the wheel half in the press as shown in the adjacent figure being sure to support the wheel half at the bottom of the bearing seat. Failure to do this may result in breakage of the wheel casting if too much force is applied.
- 7.4. Press the bearing race into the wheel until it is fully seated.
- 7.5. Remove the wheel from the press and visually check to see that the race is fully seated and that it is tight in the wheel.

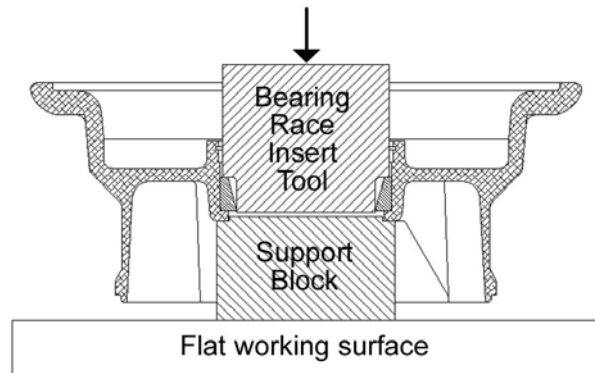

8. Inspection and Repair of Brake Drum or Brake Disc

- 8.1. If the wheel is equipped with drum brakes, inspect and repair in accordance with B.F. Goodrich Installation, Maintenance, and Overhaul Manual 1441 dated 30 April 1965.
- 8.2. If the wheel is equipped with a Grove STC SA01704LA Disc Brake Conversion, inspect and repair in accordance with the STC's Instruction for Continued Airworthiness which can be found at groveaircraft.com.

9. Reassembly of the Wheel

- 9.1. Ensure that the wheel is clean and dry. Particular attention should be paid to the bead area to ensure that it is clean, dry and free of grease or other contamination.
- 9.2. Insert the inner tube into the tire. Align the red dot on the tire (its lightest point) with the white or yellow dot on the tube (its heaviest point). If the tube does not have a white dot, align the red dot on the tire with the valve stem of the tube. In order to allow the tube to move freely within the tire, it is recommended that you lightly coat the tube and inner part of the tire with talc powder.
- 9.3. Inflate the inner tube to approximately 10 psi, allowing it to take the shape of the tire. Deflate the tire to the point that it just retains its shape.
- 9.4. Place the tire and tube onto the outer wheel half carefully inserting the valve stem through the hole in the wheel half.
- 9.5. Insert the inner wheel half into the tire with the tie bolt holes aligned and using care not to pinch the inner tube.
- 9.6. Insert the three tie bolts, with washers under the heads, through the wheel.
- 9.7. Rotate the wheel from the working surface in order to be able to attach the nuts to the tie bolts. Hand tighten a nut with washer on each of the tie bolts. Care should be taken to ensure that the wheel halves are in contact with each other and not pinching the inner tube.
- 9.8. Tighten the tie bolt nuts to a torque value of 90 inch-pounds. Observe the amount of torque required to turn the nut due to the locking friction of the nut and add this to torque requirements to get the proper torque wrench reading.
- 9.9. Repack the bearings using MIL-G-81322 grease such as Aeroshell 22, Mobil 28, or equivalent.
- 9.10. With the wheel on a flat working surface, insert a wheel bearing. Lightly coat the bearing race with bearing grease before installing the bearing.
- 9.11. Install the washers, felt grease seal and retention snap ring. A light coat of light weight oil on the felt grease seal is recommended.
- 9.12. Turn the wheel over and repeat steps 9.10. and 9.11.
- 9.13. Place the wheel in a protective enclosure and inflate to 25 psi. Deflate the tire by depressing the valve stem plunger and re-inflate to the pressure recommended by the aircraft manufacturer.

10. Reinstalling the Wheel on the Aircraft

- 10.1. Inspect the axle to ensure that it is clean, dry and in serviceable condition.
- 10.2. Install the wheel onto the axle.
- 10.3. Install the axle nut and hand tighten ensuring that the wheel bearings are fully seated on the axle.
- 10.4. While slowly rotating the wheel, tighten the axle nut until it is hand tight. Care must be taken to ensure that the valve stem is not damaged during this process.
- 10.5. Check that wheel runs free, or with very little drag. If not, loosen the axle nut only enough so that the wheel runs free, or with little drag.
- 10.6. Align the axle nut to the nearest hole in the nut with the cotter pin slot in the axle. If you need to move the nut for alignment, first try to tighten it. If the wheel still moves with little or no resistance, use that alignment. If there is increased resistance to rotation, loosen the nut to the next hole.
- 10.7. Install a new cotter pin. One end of the cotter pin should fold out and bend over the end of the axle to its center. The other end should be bent back toward the wheel and shortened if necessary to avoid contact with the wheel. Extreme care must be taken to ensure that the cotter pin does not interfere with the valve stem or other parts of the wheel when the wheel is rotated.
- 10.8. Reinstall the wheel hub cap if so equipped.
- 10.9. If aircraft is equipped with Grove brake disc STC, install brake caliper IAW Grove STC Instructions for Continued Airworthiness.
- 10.10. Rotate the wheel to ensure that it is secure and rotates freely.
- 10.11. Lower the aircraft to the ground following aircraft manufacturer's instructions.

10. Protective Coatings

If the protective coating of the wheel is damaged, it should be repaired in the following manner:

- 10.1. Aluminum Wheels: Anodize per MIL-STD-8625 Type IIB Class 1 or Alodine per MIL-C-5541 Class 1A and paint with Cardinal Industrial Paint 6424-69147 S/G Met Silver or 6409-10.1 Gloss White.
- 10.2. Magnesium: Dichromate Finish (Dow #7) per MIL-M-3171 Type 3 and paint with Cardinal Industrial Paint 6424-69147 S/G Met Silver or 6409-10.1 Gloss White.